



**INFORMATION BULLETIN**

#

**V341/1b/R1  
V541/1b/R1  
V546/2b**

- Scope:* Possible replacement of propeller boss crown nut of drawing no. V546-0003 with split pins drawing no. 2x22 CSN 02 1781.04 with nuts drawing no. V341-0003 with binding wire locking the nuts for propellers V341, V541 and V546 in all versions produced by LOM PRAHA s.p. The propellers shall continue getting furnished with the nuts draw.no. V341-0003 in production or repair.
- Justification:* Easier locking and unlocking of the propeller boss nuts drawing no. V341-0003 with binding wire at assembling/disassembling the propeller.
- Provisions:* Should the nuts drawing no. V341-0003 and binding wire KR 0,8 L-AKVS.4 CSN 42 6403/17 246.4/ (see Figure) be used to replace the crown nuts draw.no. V546-0003 and the split pins draw.no. 2x22 CSN 02 1781.04 (see propeller boss assembly and disassembly procedures, chap. II of the Manual), tighten the nuts with the specified torque of (40 – 50) Nm / (29.5 – 36.9) lb-ft and lock with binding wire as shown in the figure.
- Responsible for carrying out:* The users of V341, V541 and V546 in all versions utilizing crown nuts draw.no. V546-0003 may order the nuts of draw.no. V341-0003 as necessary.
- Material:* shall be supplied by LOM PRAHA s.p. as ordered
- Cost:* shall be paid by the propeller users if ordered the nuts of draw.no. V341-0003
- Validity:* on the date of bulletin reception

*Given in Prague on 28/04/2004*

Ing. Jiri Velisek  
Quality Manager

Ing. Vratislav Maslo.  
Director

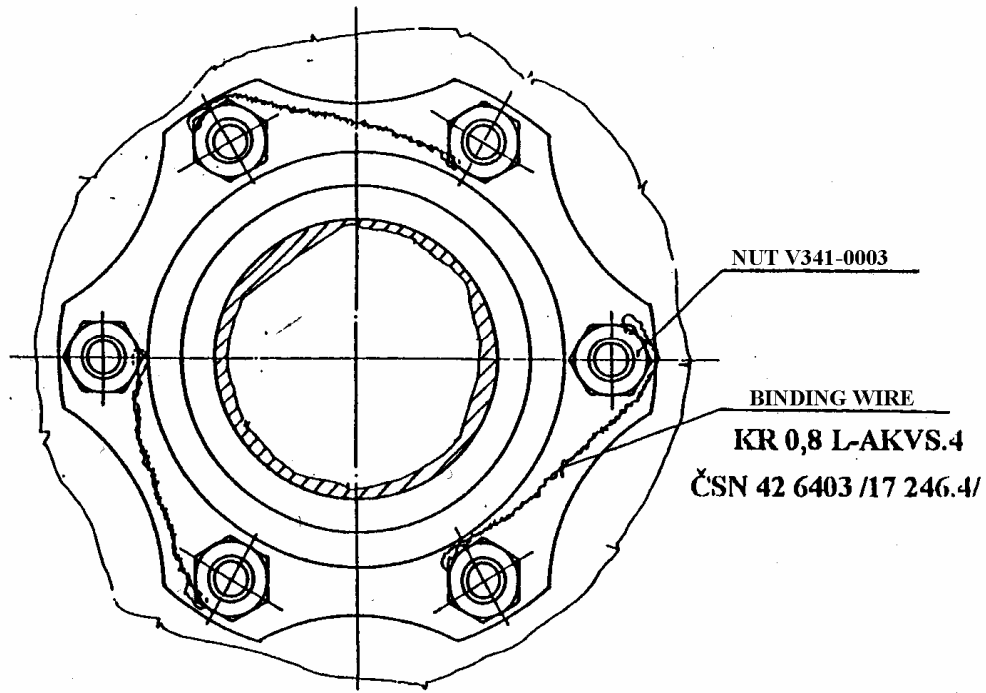

**PROPELLER BOSS NUTS LOCKING – REAR VIEW**  
draw.no. V341-0003