



INFORMATION BULLETIN

M 137 A/11
M 137 AZ/5
No. M 337 A/5

CONCERNS: Service introduction of an improved modified fuel injection pump, type LUN 5150.01, serviceable for the aeroengines of types M 137 A, M 137 AZ and M 337 A.

REASON: Improvement of air-bleeding of the fuel injection pump.

MEASURES: Since the year 1977 are the aeroengine types stated above provided with new improved modified fuel injection pumps of type LUN 5150.01 instead of the originally used injection pumps of type LUN 5150.

Only the inner design layout of the original injection pump has been modified and, this modification has no influence on the attachment of the pump and on its building-in applicability to the fuselage installation. All the other parameters of the modified fuel injection pump are identical with the technical specification of the original LUN 5150 fuel injection pump as stated in the Manual "Technical Description, Servicing and Maintenance of the Engine".

Prague, 18. 8. 1977.

M. Adamec m.p.

.....
Engine Manufacturers'
Representative

Ing. B. Homola m.p.

.....
Customer's Representative
at Engine Manufacturers

Ing. P. Hýla m.p.

.....
State Aviation Inspection

V. Houdek m.p.

.....
OMNIPOL

LUN 5150

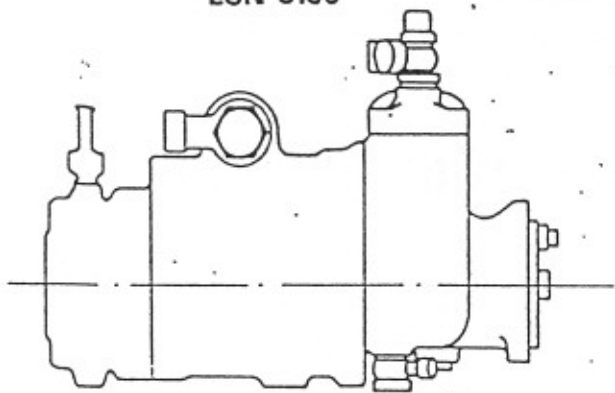

LUN 5150.01

